

æ
arbonne.®



SUCCESSPLAN | U.S.

as of January 2021

OVERVIEW

The Arbonne compensation plan, which we call the SuccessPlan, provides an opportunity for you to earn by selling products to your own Clients, building a team and teaching your team to do the same. It takes time, effort and activity to build your Arbonne business, so however much or little of these factors you choose to devote will determine your earnings and success levels. You can benefit from building a team – whether you want to focus on or expand your personal sales. The more you help your team grow their sales volume (by focusing on improving sales with their Clients), the more you will be rewarded as you move through the SuccessPlan.

How You Earn

Arbonne Independent Consultants earn in 4 ways through our SuccessPlan:

- 1 Client Commissions** are the profits paid to you on personal product sales to your Clients (35% of Suggested Retail Price, or SRP) and Preferred Clients (15% of SRP)
- 2 Overrides** are paid to you on the product sales volume of your team, made to their Clients and Preferred Clients
- 3 Achiever Awards** are available at each level based on personal and/or team product sales when you build a team and your team makes sales
- 4 Vice President Success Award** is available only to Vice Presidents and based on the Vice President's team product sales volume

In addition to these earnings opportunities in the SuccessPlan, Arbonne may offer **incentives** and **reward** and **recognition programs** for its Arbonne Independent Consultants. Refer to the information in your Arbonne My Office website for applicable offers.

KEY CONCEPTS FOR UNDERSTANDING COMPENSATION BENEFITS

All Arbonne products have a Suggested Retail Price (SRP), Retail Volume (RV), and Qualifying Volume (QV). These help you understand your earnings and benefits:

- **SRP** – This is used to calculate product discounts and Client and Preferred Client Commissions paid for product sales.
- **RV** – This is used to calculate Override Volume (OV).
- **OV** – This is used to calculate the overrides paid for product sales. **OV is 65% of RV.**
- **QV** – This is used to calculate volume from product sales to qualify for promotions and maintenance of the titles in the SuccessPlan, as well as incentives and other rewards. It is the universal point system that we standardize across each country.

Please note that Starter Kits, Business Aids, business fees (i.e., registration and renewal fees), sample packs, and product specials do not have RV or QV. Therefore, items without RV or QV do not generate commissions and overrides and do not count toward qualification or maintenance. Discounted or value priced product sets or other product specials may have reduced RV and QV and reduced Client and Preferred Client commissions.

Qualified Status: At all levels of the SuccessPlan, you need to achieve "Qualified Status" by accumulating 150 Personal Qualifying Volume (PQV) each month to receive overrides (500 PQV for paid-as Consultants to receive an override), awards and other incentives and to qualify for a promotion to and maintain the team management levels at Arbonne, which are District Manager and above.

Personal Qualifying Volume (PQV): PQV equals the QV from products sales through your Arbonne account and the product sales to your personally registered Clients and Preferred Clients.

THERE ARE NO GUARANTEES REGARDING EARNINGS. YOU SHOULD NOT BELIEVE ANYONE WHO GUARANTEES ANY AMOUNT OF EARNINGS TO YOU. EACH ARBONNE INDEPENDENT CONSULTANT, LIKE IN ANY OTHER BUSINESS, CAN SUCCEED OR FAIL FOR MANY REASONS, INCLUDING SKILL, BUSINESS ACUMEN AND LEADERSHIP. MOST PEOPLE WHO JOIN AS AN INDEPENDENT CONSULTANT DO NOT ACHIEVE EARNINGS. EVERY BUSINESS VENTURE HAS RISKS AND ARBONNE IS NO EXCEPTION. ACTUAL EARNINGS AT EACH LEVEL OF THE ARBONNE SUCCESSPLAN FOR THE LAST FISCAL YEAR ARE AVAILABLE AT EARNINGS.ARBONNE.COM.

CONSULTANT – FIRST STEP TOWARD SUCCESS

Each Arbonne Independent Consultant begins at the first level in the SuccessPlan as an Independent Consultant (IC). Most earnings at this level will come from personal sales to Clients and Preferred Clients (PC). You have the ability to increase your potential earnings when you personally register other Arbonne Independent Consultants who also sell Arbonne products to their own Clients and Preferred Clients. There is no limit to how many Clients and Preferred Clients you can register or how many Arbonne Independent Consultants you can register, who also build their own teams.

EARNINGS

- 35% discount on the SRP of Arbonne products
- 35% Client Commission
- 15% Preferred Client Commission
- 6% override on the Override Volume (OV) from the product sales of your **personally registered** Independent Consultants when you accumulate 500 PQV in the same month
- \$100 Independent Consultant Achiever Award when you personally register a minimum of two new Independent Consultants or Preferred Clients, who each accumulate at least 150 PQV in product sales in their Start Month, and in the same month, you accumulate 150 PQV and 2,500 SuccessLine Qualifying Volume (SLQV)

EARNINGS AT A GLANCE

Client Commission	35%
PC Commission	15%
Consultant Override (when you begin building your business and accumulate 500 PQV in the same month)	6%

CL = Client

PC = Preferred Client

IC = Independent Consultant

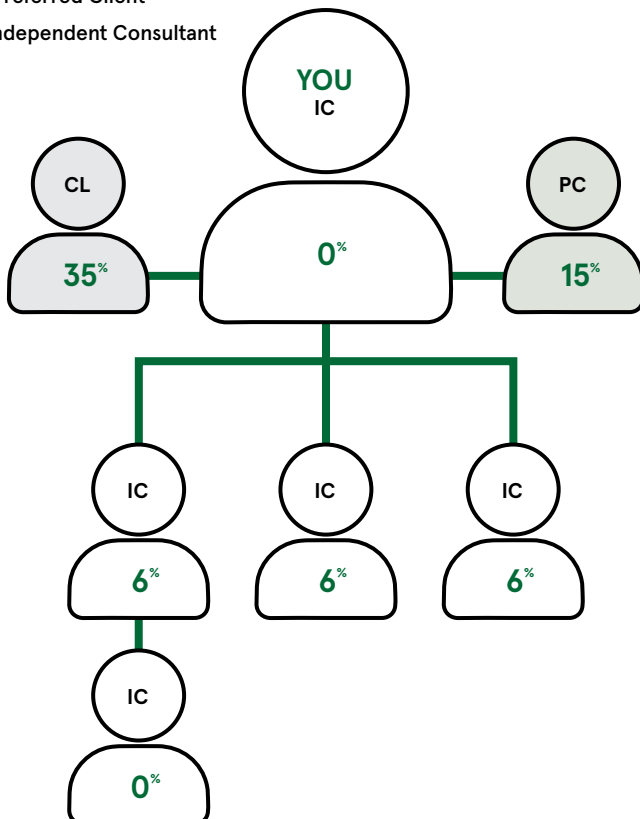

KEY CONCEPTS

SuccessLine Qualifying Volume (SLQV): Your PQV plus the PQV from all the Arbonne Independent Consultants who have been registered below you, unless they have promoted to a higher title in the SuccessPlan. Thus, the promoted Arbonne Independent Consultants and anyone registered below are excluded from your SLQV.

Personal Qualifying Volume (PQV): PQV equals the QV from products sales through your Arbonne account and the product sales to your personally registered Clients and Preferred Clients.

Frontline and Width: There is no limit to the amount of people you can personally register as an Independent Consultant or register as a Preferred Client or Client. Independent Consultants you personally register are your frontline and create width in your business, which maximizes your override opportunities.

Now that you're earning as a Consultant, it's time to focus on promoting to the next level, District Manager.

STEPPING UP TO DISTRICT MANAGER

Promote to District Manager

You can promote to District Manager by meeting the volume requirements over a **one-, two- or three-month period**. Choose your own pace, take your time and enjoy the journey. Each qualification journey also has an Advanced Track to Area Manager option.

One Month – Qualify in one month period when you achieve:

- 1,000 PQV and
- 6,000 SLQV

Two Months – Qualify over a consecutive two-month period when you accumulate over the two months:

- 1,000 PQV and
- 6,000 SLQV
- Month 1: 1,000 PQV or 2,500 SLQV to start the qualification period
- Month 2: 2,500 SLQV in your last month
- Each Month: 150 PQV

Three Months – Qualify over a consecutive three-month period when you accumulate over all three months:

- 1,000 PQV and
- 7,500 SLQV
- Month 1: 1,000 PQV or 2,500 SLQV to start the qualification period
- Month 3: 2,500 SLQV in your last month
- Each Month: 150 PQV

PICK-UP CREDIT

If you have personally registered and helped any Arbonne Independent Consultants who are already paid-as District Managers or above, then you can apply a 650 QV pick-up credit to count toward your SLQV requirement each applicable month during your qualification period. Maximum one 650 credit, regardless of how many you have promoted.

EXAMPLES

	PQV	SLQV	
			ONE-MONTH EXAMPLE
Month 1:	1,000	6,000*	Met 1,000 PQV and 6,000 SLQV to complete in 1 month

**If applicable, you may apply a 650 QV pick-up credit*

	PQV	SLQV	
			TWO-MONTH EXAMPLE
Month 1:	150	2,500*	Met 150 PQV and 2,500 SLQV to enter qualification
Month 2:	850	3,500*	Met 150 PQV and 2,500 SLQV in the last month
Total:	1,000	6,000	Met 1,000 PQV and 6,000 SLQV over 2 months to complete

**If applicable, you may apply a 650 QV pick-up credit*

	PQV	SLQV	
			THREE-MONTH EXAMPLE
Month 1:	150	2,500*	Met 150 PQV and 2,500 SLQV to enter qualification
Month 2:	350	1,500*	Met 150 PQV
Month 3:	500	3,500*	Met 150 PQV and 2,500 SLQV in the last month
Total:	1,000	7,500	Met 1,000 PQV and 7,500 SLQV over 3 months to complete

**If applicable, you may apply a 650 QV pick-up credit*

ADVANCED TRACK QUALIFICATION

If you complete one of the qualification options above and in the last month of your qualification you have a minimum of 10,000 SLQV, you will also complete your first qualification month toward Area Manager. The pick-up credit for Area Manager qualifications cannot be applied to the 10,000 SLQV for this Advanced Track option.

Now You're a District Manager

As a District Manager, you're building your business with personal sales, while simultaneously building a team of Arbonne Independent Consultants. Your team is your "Central District." This includes your own product sales to your Clients and Preferred Clients because you are part of your team. When you help others promote to District Manager, they will move out of your Central District team to form their own Central District teams, which become "1st Generation Districts" to you. You are now an **Executive District Manager** and will earn on the product sales of not only your Central District but also your 1st Generation Districts, as well as any Districts they promote up to three Generations deep when you maximize the SuccessPlan.

EARNINGS

- 35% discount on the SRP of Arbonne products
- 35% Client Commission
- 15% Preferred Client Commission
- 8% Override on your Central District OV
- 8% Override on all your 1st Generation Districts' OV
- 2% Override on all your 2nd Generation Districts' OV, when you have two or more 1st Generation District Managers
- 1% Override on all your 3rd Generation Districts' OV, when you have three or more 1st Generation District Managers
- \$200 District Manager Achiever Award with Central District sales of 5,000 QV and minimum 5 new Independent Consultants or Preferred Clients in your Central District who accumulate at least 150 PQV in product sales to their own Clients or Preferred Clients, each in their Start Month



ARBONNE INDEPENDENT CONSULTANTS

LORI LUCERO
EXECUTIVE NATIONAL
VICE PRESIDENT

JENNIFER MITCHELL
REGIONAL VICE PRESIDENT

KENDYLL TRAVERS
EXECUTIVE NATIONAL
VICE PRESIDENT

ALYSSA CAVALLARO
NATIONAL VICE PRESIDENT

BASSAMBA SAO
NATIONAL VICE PRESIDENT

EARNINGS AT A GLANCE

Client Commission	35%
PC Commission	15%
Overrides	District
Central	8%
1st Generation	8%
2nd Generation	2%
3rd Generation	1%

 District
 DM = District Manager
 EDM = Executive District Manager

Central District:

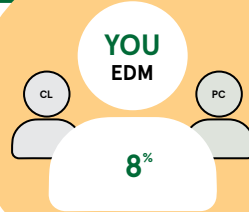

Your Central District comprises you (including volume from your PCs and Clients), your personally registered Independent Consultants, and all other Independent Consultants registered by them and so on that have not yet reached the title of District.

1st Generation

EDM
8%

DM
8%

DM
8%

2nd Generation

EDM
2%

3rd Generation

EDM
1%

4th Generation

DM
0%



MAINTENANCE

As a District Manager, you will need to achieve **2,500 Central District QV** each month. See page 16 for full details.



Tip: Now that you are a paid-as District Manager, all Consultants in your SuccessLine now fall into your Central District, as long as they are not paid-as District Managers or above.

KEY CONCEPTS

Pick-Up Credit: This is a volume credit you receive, for purposes of calculating qualification for titles only and not compensation, when your 1st Generation Manager/VP promotes to a higher title in the SuccessPlan than you. You can apply a maximum of one pick-up credit, regardless of how many you have promoted, to count toward your QV requirement each applicable month during your qualification period.

Executive: When you promote a Consultant from your Central District to your 1st Generation District, you become an Executive District Manager.

As you grow your team sales, you will step up to the next level in the SuccessPlan, Area Manager.

STEPPING UP TO AREA MANAGER

Promote to Area Manager

You can promote to Area Manager by meeting the volume requirements over a **two-** or **three-month period**. Again, your pace is up to you and you will decide when the time is right. Each qualification journey also has an Advanced Track to Regional Vice President option.

Two Months – Qualify over a consecutive two-month period

- Accumulate a total of 24,000 QV over both months
- Month 1: 10,000 QV to start the qualification period
- Month 2: 10,000 QV in your last month
- Each Month:
 - 150 PQV
 - 2,500 Central District QV

Three Months – Qualify over a consecutive three-month period

- Accumulate a total of 30,000 QV over all three months
- Month 1: 10,000 QV to start the qualification period
- Month 2: 2,500 QV
- Month 3: 10,000 QV in your last month
- Each Month:
 - 150 PQV
 - 2,500 Central District QV

QUALIFYING AS AN EXECUTIVE DISTRICT MANAGER

After you have achieved 2,500 QV in your own Central District, then you may count a maximum of 10,000 QV from each 1st Generation paid-as District Manager’s entire SuccessLine, excluding volume from 1st Generation Districts’ promoted-out Area Managers or above, to help you reach your total QV goal during the qualification period.

Pick-Up Credit: If you have any 1st Generation District Managers who are already paid-as Area Managers or above, then you can apply a 2,500 QV pick-up credit to count toward your QV requirement each month. Maximum one 2,500 credit, regardless of how many you have promoted. The pick-up credit of 2,500 QV will only be available for you to use after you’ve already reached 2,500 Central District QV without applying the credit. If your 1st Generation District Manager promotes to Area Manager during your qualification period, the 2,500 QV pick-up credit will be included in the maximum 10,000 QV that you may count over the qualification period for your total QV.

EXAMPLES

	PQV	Central District QV	District SLQV	
TWO-MONTH EXAMPLE				
Month 1:	150	10,000*	10,000	Met 150 PQV, 2,500 Central District QV and 10,000 QV to enter qualification
Month 2:	150	14,000*	14,000	Met 150 PQV, 2,500 Central District QV and 10,000 QV in the last month
Total:		24,000	24,000	Met 24,000 QV over 2 months to complete

**If applicable and after you’ve reached 2,500 Central District QV, you may apply up to 10,000 QV from each of your 1st Generation DMs, over the qualification period, and/or apply a 2,500 QV pick-up credit QV each month.*

	PQV	Central District QV	District SLQV	
THREE-MONTH EXAMPLE				
Month 1:	150	10,000*	10,000	Met 150 PQV, 2,500 Central District QV and 10,000 QV to enter qualification
Month 2:	150	9,000*	9,000	Met 150 PQV and 2,500 Central District QV
Month 3:	150	11,000*	11,000	Met 150 PQV, 2,500 Central District QV and 10,000 QV in the last month
Total:		30,000	30,000	Met 30,000 QV over 3 months to complete

**If applicable and after you’ve reached 2,500 Central District QV, you may apply up to 10,000 QV from each of your 1st Generation DMs, over the qualification period, and/or apply a 2,500 QV pick-up credit QV each month.*

TWO-MONTH EXAMPLE WITH 1ST GENERATION DM

	PQV	Central District QV	District SLQV	
Month 1:	150	6,500*	10,000	Met 150 PQV, 2,500 Central District QV and 10,000 QV, which includes 1st Gen DM's QV, to enter qualification
<i>1st Gen DM:</i>		3,500		Counted 3,500 from the maximum 10,000 from their 1st Gen DM (6,500 QV remaining to use)
Month 2:	150	7,500*	14,000	Met 150 PQV, 2,500 Central District QV and 10,000 QV, which includes 1st Gen DM's QV, in the last month
<i>1st Gen DM:</i>		6,500		Counted the remainder of 6,500 from the maximum 10,000 from their 1st Gen DM
Total:		24,000	24,000	Met 24,000 QV over 2 months to complete

**If applicable and after you've reached 2,500 Central District QV, you may apply up to 10,000 QV from each of your 1st Generation DMs, over the qualification period, and/or apply a 2,500 QV pick-up credit QV each month.*

THREE-MONTH EXAMPLE WITH 1ST GENERATION DM

	PQV	Central District QV	District SLQV	
Month 1:	150	8,500*	11,000	Met 150 PQV, 2,500 Central District QV and 10,000 QV, which includes 1st Gen DM's QV, to enter qualification
<i>1st Gen DM:</i>		2,500		Counted 2,500 from the maximum 10,000 from their 1st Gen DM (7,500 QV remaining to use)
Month 2:	150	3,500*	7,000	Met 150 PQV and 2,500 Central District QV
<i>1st Gen DM:</i>		3,500		Counted 3,500 from the maximum 10,000 from their 1st Gen DM (4,000 QV remaining to use)
Month 3:	150	8,000*	12,000	Met 150 PQV, 2,500 Central District QV and 10,000 QV, which includes 1st Gen DM's QV, in the last month
<i>1st Gen DM:</i>		4,000		Counted the remainder of 4,000 from the maximum 10,000 from their 1st Gen DM
Total:		30,000	30,000	Met 30,000 QV over 3 months to complete

**If applicable and after you've reached 2,500 Central District QV, you may apply up to 10,000 QV from each of your 1st Generation DMs, over the qualification period, and/or apply a 2,500 QV pick-up credit QV each month.*

ADVANCED TRACK QUALIFICATION

If you complete one of the qualifications above and in the last month of your qualification you have a minimum of 40,000 SLQV, you will also complete your first qualification month toward Regional Vice President. The pick-up credit for Region qualifications cannot be applied to the 40,000 SLQV for this Advanced Track option.

Now You're an Area Manager

As an Area Manager, you're truly managing and guiding your growing team, which now also includes your "Central Area." Your Central Area includes your Districts and anyone in your SuccessLine that has not yet promoted to Area Manager or above. Anyone you promote to Area Manager will move out of your Central Area team to form their own Central Area teams, which become "1st Generation Areas" to you. You are now an **Executive Area Manager** and will earn on the product sales of not only your Central Area, but also your 1st Generation Areas, and any Areas they promote up to three Generations deep when you maximize the SuccessPlan. This is in addition to the Client and Preferred Client Commissions and District Overrides you are already earning.

EARNINGS

All District Manager benefits and earnings, **PLUS:**

- 6% Override on your Central Area OV
- 6% Override on all your 1st Generation Areas' OV
- 1% Override on all your 2nd Generation Areas' OV, when you have two or more 1st Generation Area Managers
- 1% Override on all your 3rd Generation Areas' OV, when you have three or more 1st Generation Area Managers
- \$400 Area Manager Achiever Award with Central Area sales of 20,000 QV and minimum 10 new Independent Consultants or Preferred Clients in your Central Area who accumulate at least 150 PQV in product sales to their own Clients or Preferred Clients, each in their Start Month. You will receive the greater of the District Manager or Area Manager Achiever Award if you qualify for both.

EARNINGS AT A GLANCE

Client Commission	35%	
PC Commission	15%	
Overrides	District	Area
Central	8%	6%
1st Generation	8%	6%
2nd Generation	2%	1%
3rd Generation	1%	1%

● District ● Area

AM = Area Manager

EAM = Executive Area Manager

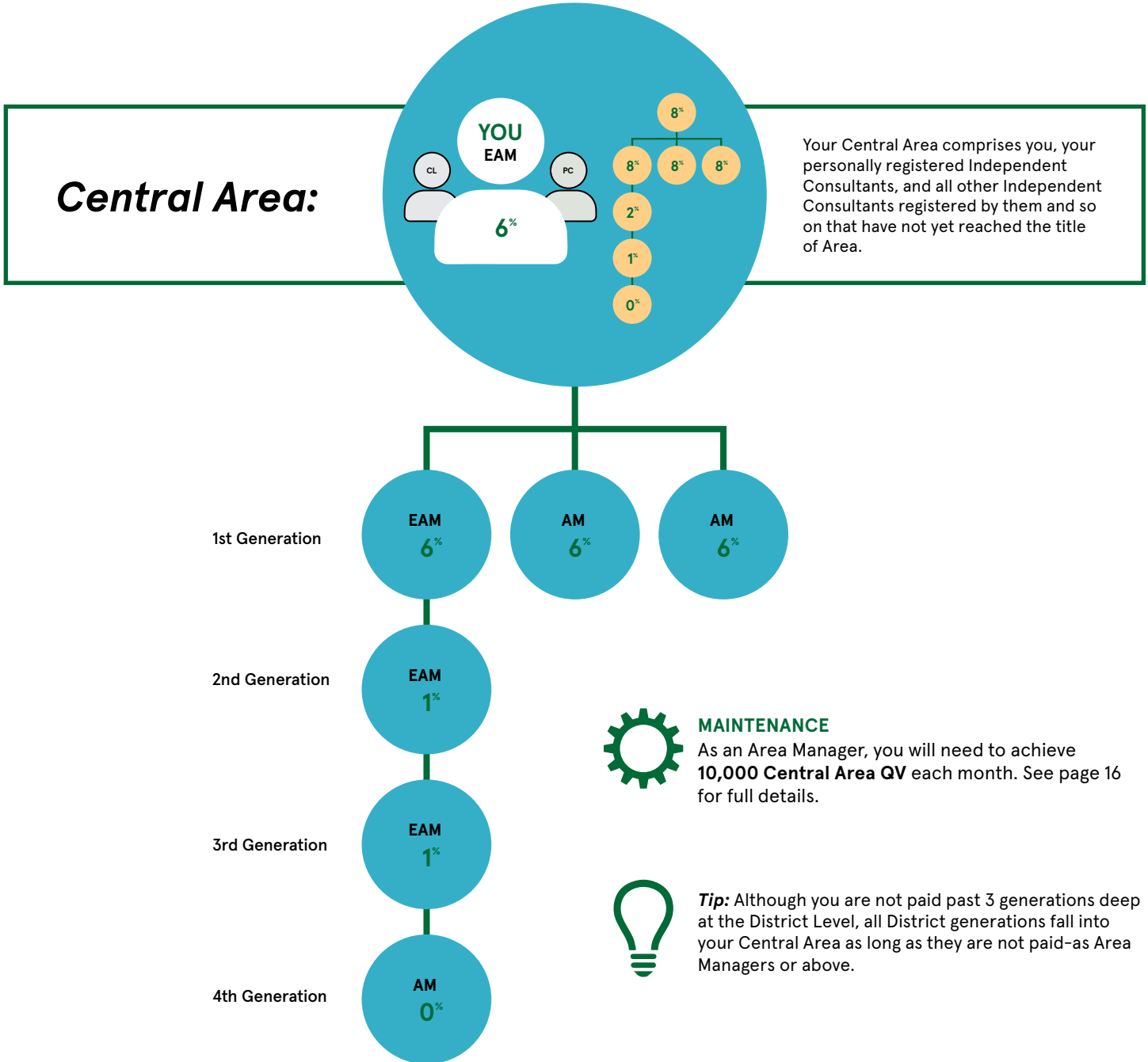

Your Central Area comprises you, your personally registered Independent Consultants, and all other Independent Consultants registered by them and so on that have not yet reached the title of Area.



MAINTENANCE

As an Area Manager, you will need to achieve **10,000 Central Area QV** each month. See page 16 for full details.



Tip: Although you are not paid past 3 generations deep at the District Level, all District generations fall into your Central Area as long as they are not paid-as Area Managers or above.

KEY CONCEPTS

Executive: When you promote a District Manager from your Central Area to your 1st Generation Area, you become an Executive Area Manager.

Now that you've learned how to manage a team, now it's time to step up to a leadership position at Regional Vice President.

STEPPING UP TO REGIONAL VICE PRESIDENT

Promote to Regional Vice President

You can promote to Regional Vice President by meeting the volume requirements over a **two- or three-month period**. Each qualification journey also has an Advanced Track to National Vice President option.

Two Months – Qualify in two consecutive months

- Accumulate a total of 96,000 QV over both months
- Each Month:
 - 150 PQV
 - 40,000 QV

Three Months – Qualify in three consecutive months

- Accumulate a total of 120,000 QV over all three months
- Month 1: 40,000 QV to start the qualification period
- Month 3: 40,000 QV in your last month
- Each Month: 150 PQV

QUALIFYING AS AN EXECUTIVE AREA MANAGER

You may count a maximum of 40,000 QV from each 1st Generation paid-as Area Manager’s entire SuccessLine, excluding volume from 1st Generation Areas’ promoted-out Regional Vice Presidents, to help you reach your total QV goal during the qualification period.

Pick-Up Credit: If you have any 1st Generation Areas who are already paid-as Regional Vice Presidents or above, then you can apply a 10,000 QV pick-up credit to count toward your QV requirement each month. Maximum one 10,000 credit, regardless of how many you have promoted. If your 1st Generation Area Manager promotes to Regional Vice President during your qualification period, the 10,000 QV pick-up credit will be included in the maximum 40,000 QV that you may count over the qualification period for your total QV.

EXAMPLES

	PQV	Central Area QV	Area SLQV	
				TWO-MONTH EXAMPLE
Month 1:	150	40,000*	40,000	Met 150 PQV and 40,000 QV to enter qualification
Month 2:	150	56,000*	56,000	Met 150 PQV and 40,000 QV in the last month
Total:		96,000	96,000	Met 96,000 QV over 2 months to complete

**If applicable, you may apply up to 40,000 QV from your 1st Generation AMs over the qualification period and/or apply a 10,000 QV pick-up credit each month.*

	PQV	Central Area QV	Area SLQV	
				THREE-MONTH EXAMPLE
Month 1:	150	40,000*	40,000	Met 150 PQV and 40,000 QV to enter qualification
Month 2:	150	35,000*	35,000	Met 150 PQV
Month 3:	150	45,000*	45,000	Met 150 PQV and 40,000 QV in the last month
Total:		120,000	120,000	Met 120,000 QV over 3 months to complete

**If applicable, you may apply up to 40,000 QV from your 1st Generation AMs over the qualification period and/or apply a 10,000 QV pick-up credit each month.*

	PQV	Central Area QV	Area SLQV	
				TWO-MONTH EXAMPLE WITH 1ST GENERATION AM
Month 1:	150	20,000*	40,000	Met 150 PQV and 40,000 QV, which includes 1st Gen AM’s QV, to enter qualification
<i>1st Gen AM:</i>		20,000		Counted 20,000 from the maximum 40,000 from their 1st Gen AM (20,000 QV remaining to use)
Month 2:	150	36,000*	56,000	Met 150 PQV and 40,000 QV, which includes 1st Gen AM’s QV, in the last month
<i>1st Gen AM:</i>		20,000		Counted the remainder of 20,000 from the maximum 40,000 from their 1st Gen AM
Total:		96,000	96,000	Met 96,000 QV over 2 months to complete

**If applicable, you may apply up to 40,000 QV from your 1st Generation AMs over the qualification period and/or apply a 10,000 QV pick-up credit each month.*

THREE-MONTH EXAMPLE WITH 1ST GENERATION AM

	PQV	Central Area QV	Area SLQV	
Month 1:	150	20,000*	40,000	Met 150 PQV and 40,000 QV, which includes 1st Gen AM's QV, to enter qualification
<i>1st Gen AM:</i>		20,000		Counted 20,000 from the maximum 40,000 from their 1st Gen AM (20,000 QV remaining to use)
Month 2:	150	20,000*	30,000	Met 150 PQV
<i>1st Gen AM:</i>		10,000		Counted 10,000 from the maximum 40,000 from their 1st Gen AM (10,000 QV remaining to use)
Month 3:	150	40,000*	50,000	Met 150 PQV and 40,000 QV, which includes 1st Gen AM's QV, in the last month
<i>1st Gen AM:</i>		10,000		Counted the remainder of 10,000 from the maximum 40,000 from their 1st Gen AM
Total:		120,000	120,000	Met 120,000 QV over 3 months to complete

**If applicable, you may apply up to 40,000 QV from your 1st Generation AMs over the qualification period and/or apply a 10,000 QV pick-up credit each month.*

ADVANCED TRACK QUALIFICATION

If you complete one of the qualifications above and in the last month of your qualification you have a minimum of 160,000 SLQV, you will also complete your first qualification month for National Vice President. The pick-up credit for Nation qualifications cannot be applied to the 160,000 SLQV for this Advanced Track option.

Now You're a Regional Vice President

As a Regional Vice President, you have stepped up to a leadership role. Your team now also includes your "Central Region." Your Central Region includes your Areas and anyone in your SuccessLine that has not yet promoted to Regional Vice President and above. Anyone you also promote to Regional Vice President will move out of your Central Region team to form their own Central Region teams, which become "1st Generation Regions" to you. You are now an **Executive Regional Vice President** and will earn on the product sales of your Central Region, your 1st Generation Regions, and any Regions they promote up to three Generations deep when you maximize the SuccessPlan. This is in addition to the Client and Preferred Client Commissions, District Overrides, and Area Overrides you are already earning.

EARNINGS

District Manager and Area Manager benefits and earnings, **PLUS:**

- 3% Override on your Central Region OV
- 3% Override on all your 1st Generation Regions' OV
- 2% Override on all your 2nd Generation Regions' OV, when you have two or more 1st Generation Regional Vice Presidents
- 2% Override on all your 3rd Generation Regions' OV, when you have three or more 1st Generation Regional Vice Presidents
- \$600 Vice President Achiever Award with Central Region sales of 60,000 QV and minimum 30 new Independent Consultants and/or Preferred Clients in your Central Region who accumulate at least 150 PQV in product sales to their own Clients or Preferred Clients, each in their Start Month. You will receive the greater of the District Manager, Area Manager, or Vice President Achiever Award when you qualify for more than one.
- The RVP Success Award is available to all RVPs when the RVP provides documentation that he or she has purchased or leased a white Mercedes-Benz automobile, has affixed the Arbonne car emblem to the automobile, and each month meets the following Central Region QV requirements.

Central Region QV + RVP promotion credits	=	RVP Success Award
40,000	=	\$800
35,000	=	\$600
30,000	=	\$400
25,000	=	\$200

EARNINGS AT A GLANCE

Client Commission	35%		
PC Commission	15%		
Overrides	District	Area	Region
Central	8%	6%	3%
1st Generation	8%	6%	3%
2nd Generation	2%	1%	2%
3rd Generation	1%	1%	2%

● District
 ● Area
 ● Region

RVP = Regional Vice President

ERVP = Executive Regional Vice President

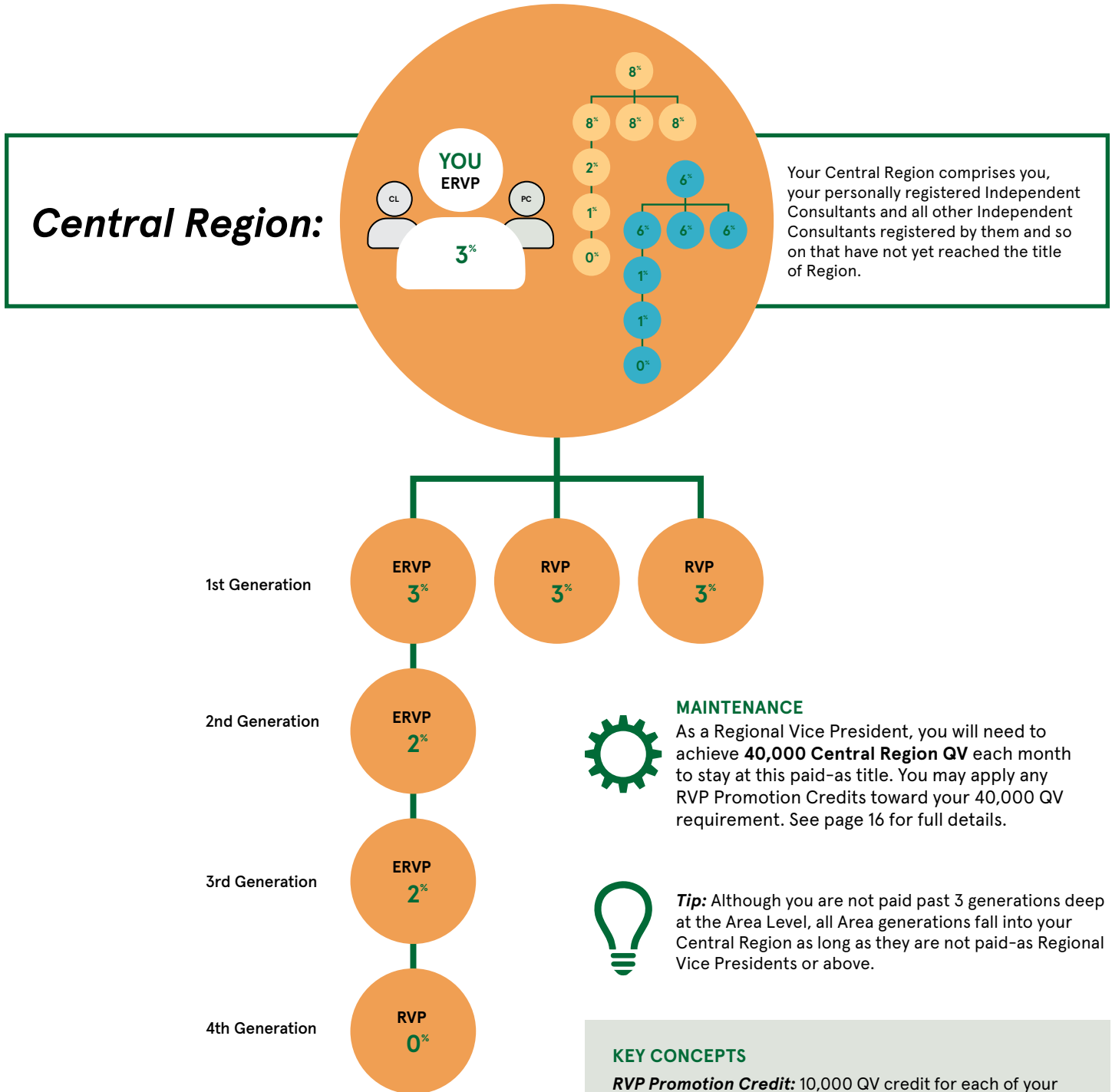

STEPPING UP TO NATIONAL VICE PRESIDENT

Promote to National Vice President

You can promote to National Vice President when your product sales meet the volume requirements over a **two- or three-month period**.

Two Months – Qualify in two consecutive months

- Accumulate a total of 384,000 QV over both months
- Each Month:
 - 150 PQV
 - 160,000 QV

Three Months – Qualify in three consecutive months

- Accumulate a total of 480,000 QV over all three months
- Month 1: 160,000 on QV to start the qualification period
- Month 3: 160,000 QV in your last month
- Each Month: 150 PQV

QUALIFYING AS AN EXECUTIVE REGIONAL VICE PRESIDENT

You may count a maximum of 160,000 QV from each 1st Generation paid-as Regional Vice President’s entire SuccessLine, excluding volume from 1st Generation Regions’ promoted-out National Vice Presidents, to help you reach your total QV goal during the qualification period.

Pick-Up Credit: If you have any 1st Generation Regions who are already paid-as National Vice Presidents, then you can apply a 40,000 QV pick-up credit to count toward your QV requirement each month. Maximum one 40,000 credit, regardless of how many you have promoted. If your 1st Generation Regional Vice President promotes to National Vice President during your qualification period, the 40,000 QV pick-up credit will be included in the maximum 160,000 QV that you may count over the qualification period for your total QV.

EXAMPLES

	PQV	Central Region QV	Region SLQV	
TWO-MONTH EXAMPLE				
Month 1:	150	160,000*	160,000	Met 150 PQV and 160,000 QV to enter qualification
Month 2:	150	224,000*	224,000	Met 150 PQV and 160,000 QV in the last month
Total:		384,000	384,000	Met 384,000 QV over 2 months to complete

**If applicable, you may apply up to 160,000 QV from your 1st Generation RVPs over the qualification period and/or apply a 40,000 QV pick-up credit each month.*

	PQV	Central Region QV	Region SLQV	
THREE-MONTH EXAMPLE				
Month 1:	150	160,000*	160,000	Met 150 PQV and 160,000 QV to enter qualification
Month 2:	150	145,000*	145,000	Met 150 PQV
Month 3:	150	175,000*	175,000	Met 150 PQV and 160,000 QV in the last month
Total:		480,000	480,000	Met 480,000 QV over 3 months to complete

**If applicable, you may apply up to 160,000 QV from your 1st Generation RVPs over the qualification period and/or apply a 40,000 QV pick-up credit each month.*

	PQV	Central Region QV	Region SLQV	
TWO-MONTH EXAMPLE WITH 1ST GENERATION RVP				
Month 1:	150	115,000*	160,000	Met 150 PQV and 160,000 QV, which includes 1st Gen RVP’s QV, to enter qualification
<i>1st Gen RVP:</i>		45,000		Counted 45,000 from the maximum 160,000 from their 1st Gen RVP (115,000 QV remaining to use)
Month 2:	150	109,000*	224,000	Met 150 PQV and 160,000 QV, which includes 1st Gen RVP’s QV, in the last month
<i>1st Gen RVP:</i>		115,000		Counted the remainder of 115,000 from the maximum 160,000 from their 1st Gen RVP
Total:		384,000	384,000	Met 384,000 QV over 2 months to complete

**If applicable, you may apply up to 160,000 QV from your 1st Generation RVPs over the qualification period and/or apply a 40,000 QV pick-up credit each month.*

	PQV	Central Region QV	Region SLQV	
				THREE-MONTH EXAMPLE WITH 1ST GENERATION RVP
Month 1:	150	115,000*	160,000	Met 150 PQV and 160,000 QV, which includes 1st Gen RVP's QV, to enter qualification
<i>1st Gen RVP:</i>		45,000		Counted 45,000 from the maximum 160,000 from their 1st Gen RVP (115,000 QV remaining to use)
Month 2:	150	100,000	140,000	Met 150 PQV
<i>1st Gen RVP:</i>		40,000		Counted 40,000 from the maximum 160,000 from their 1st Gen RVP (75,000 QV remaining to use)
Month 3:	150	105,000*	180,000	Met 150 PQV and 160,000 QV, which includes 1st Gen RVP's QV, in the last month
<i>1st Gen RVP:</i>		75,000		Counted the remainder of 75,000 from the maximum 160,000 from their 1st Gen RVP
Total:		480,000	480,000	Met 480,000 QV over 3 months to complete

**If applicable, you may apply up to 160,000 QV from your 1st Generation RVPs over the qualification period and/or apply a 40,000 QV pick-up credit each month.*

Now You're a National Vice President

As a National Vice President, you have reached the top leadership title of Arbonne's SuccessPlan. Your Central Nation includes your Regions and anyone in your SuccessLine that has not yet promoted to National Vice President. To reach the highest level of success, you'll want to focus on developing and mentoring tomorrow's leaders to create strong and sustainable sales teams. When you help others promote to National Vice President, they will move out of your Central Nation team to form their own Central Nation teams, which become "1st Generation Nations" to you. You are now an **Executive National Vice President** and will earn on the product sales of not only your Central Nation, but also your 1st Generation Nations, and any Nations they promote up to **SIX Generations** deep when you maximize the SuccessPlan. This is in addition to the Client and Preferred Client Commissions, District Overrides, Area Overrides, and Region Overrides you are already earning. So, to truly maximize Arbonne's compensation plan, you'll need to have at least six direct National Vice Presidents (a "6-wide ENVP"). Remember, there is no limit on how many NVPs you can promote directly to you, so you can continue to grow your earnings by continuing to promote and mentor NVPs as they create more sales volume in their SuccessLines.

EARNINGS

District Manager, Area Manager, and Regional Vice President benefits and earnings, **PLUS:**

- 1% Override on your Central Nation OV
- 1% Override on all your 1st Generation Nations' OV
- 1% Override on all your 2nd Generation Nations' OV, when you have two or more 1st Generation National Vice Presidents
- 1% Override on all your 3rd Generation Nations' OV, when you have three or more 1st Generation National Vice Presidents
- 1% Override on all your 4th Generation Nations' OV, when you have four or more 1st Generation National Vice Presidents
- 1% Override on all your 5th Generation Nations' OV, when you have five or more 1st Generation National Vice Presidents
- 1% Override on all your 6th Generation Nations' OV, when you have six or more 1st Generation National Vice Presidents
- The NVP Success Award is available to all NVPs, when the NVP provides documentation that he or she has purchased or leased a white Mercedes-Benz automobile, has affixed the Arbonne car emblem to the automobile, and each month meets the following Central Nation QV requirements.

Central Nation QV + NVP promotion credits	=	NVP Success Award
160,000	=	\$1,000
140,000	=	\$800
120,000	=	\$600
100,000	=	\$400

EARNINGS AT A GLANCE

Client Commission	35%			
PC Commission	15%			
Overrides	District	Area	Region	Nation
Central	8%	6%	3%	1%
1st Generation	8%	6%	3%	1%
2nd Generation	2%	1%	2%	1%
3rd Generation	1%	1%	2%	1%
4th Generation				1%
5th Generation				1%
6th Generation				1%

● District
 ● Area
 ● Region
 ● Nation

NVP = National Vice President

ENVP = Executive National Vice President

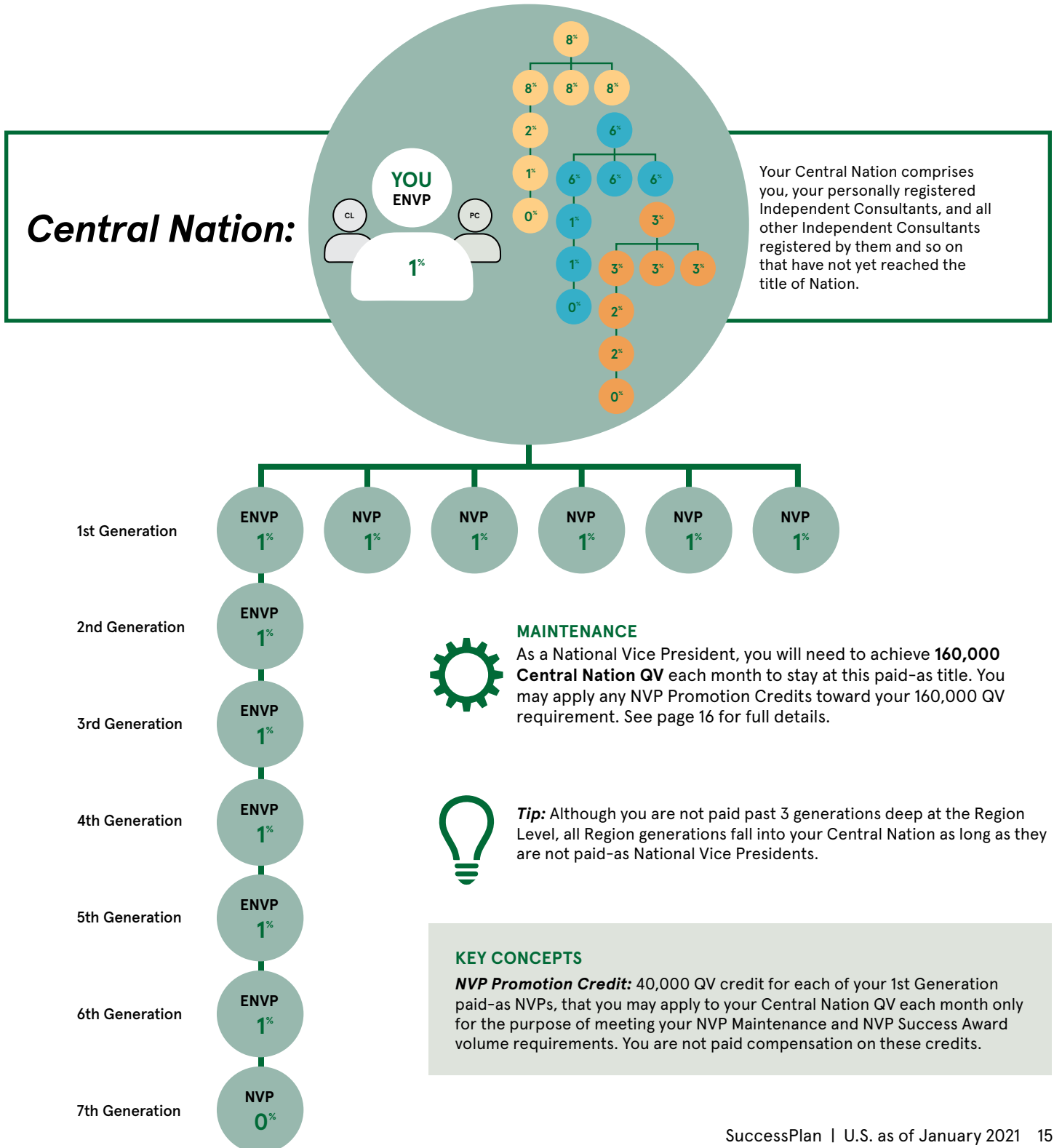

KEY CONCEPTS AND FEATURES

CENTRAL QV MAINTENANCE REQUIREMENTS

Each month, District Managers and above have a specific Central QV Maintenance requirement they need to reach to maintain their paid-as title.

- **DM:** 2,500 Central District QV
- **AM:** 10,000 Central Area QV
- **RVP:** 40,000 Central Region QV
- **NVP:** 160,000 Central Nation QV

PERFORMANCE ACCOUNTS

The Performance Account (PA) is there to assist in the months where your Central QV from product sales is lower than your Central QV Maintenance requirement. Each paid-as District Manager and above has a Performance Account where Arbonne adds or deducts QV based on the following criteria:

Monthly Central QV from Product Sales – Monthly QV Requirement = Contribution or Deduction to your PA Balance

EXAMPLES:

Central District QV	–	Monthly Maintenance	=	Contribution to PA
3,400	–	2,500	=	900
Central District QV	–	Monthly Maintenance	=	Deduction to PA
1,500	–	2,500	=	–1,000

- Upon promotion or reassignment from one level to the next, any points remaining in your PA balance will transfer to the next title with you, and you will have a two-month building period during which all Central QV from product sales is deposited into your PA without any maintenance deduction. This does not apply when a District Manager is reassigned to Consultant because there is no PA at the Consultant level, and any balance will be removed. Consultants who re-promote to District Manager will, again, have a PA, but will not regain any previous balances.
- When you promote another Arbonne Independent Consultant from your Central to your 1st Generation, paid-as title, you also receive a two-month building period during which all Central QV from product sales is deposited into your PA without any maintenance deduction.
- Paid-as Regional and National Vice Presidents will receive Promotion Credits for each 1st Generation Region or Nation, respectively, if needed to meet your paid-as monthly maintenance. These Promotion Credits are not generated by product sales and are only used for purposes of calculating Central Maintenance and VP Success Award volume. They will be added to help you reach – but not to exceed – your monthly Central QV Maintenance, and will not be contributed to the PA.

EXAMPLE:

This NVP only needed 15,000 of the 40,000 Promotion Credits to meet the 160,000 Central Nation QV for maintenance. Because product sales volume did not exceed 160,000 QV, nothing will be added to the Performance Account.

(Central Nation QV)	–	(Monthly Maintenance)	+	(Promotion Credit)	=	(Contribution to PA)
145,000	–	160,000	+	40,000	=	0

YEARLY QV LIMIT

- Each calendar year, beginning January 1 and ending December 31, there is a limit on the QV amount District Managers and above can draw from their PA to assist in maintaining their paid-as title:
 - **DM:** 7,500 QV
 - **AM:** 30,000 QV
 - **RVP:** 120,000 QV
 - **NVP:** 480,000 QV
- If you deplete your yearly QV limit before the calendar year is over, OR if your monthly QV requirement is not met and the resulting PA balance is negative, you will qualify for all benefits associated with your paid-as title that month; however, you will be reassigned to the next lower paid-as title on the first of the following month.
- Managers/Vice Presidents who promote or are reassigned to a lower paid-as title during the calendar year will have the above full amount to draw from during the remainder of the calendar year, based on their new paid-as title.

TITLE MAINTENANCE

If you are reassigned to a lower paid-as title, you will retain your higher title for recognition purposes for the period specified below. If your paid-as title is lower than your recognition title, then you are considered in "title maintenance." Managers and Vice Presidents remain in title maintenance unless you re-promote to be paid at your recognition title, or if your title maintenance period below has expired.

- District Managers – 3 months
- Area Managers – 6 months
- Regional Vice Presidents – 9 months
- National Vice Presidents – 12 months

VICE PRESIDENT SUCCESS AWARDS

For every month paid-as Vice President, you are eligible for the VP Success Award when you provide documentation that you have purchased or leased a white Mercedes-Benz automobile and have affixed the Arbonne car emblem to your automobile. You will be asked to confirm your vehicle documentation annually. Visit your Arbonne website My Office for instructions.

If you are a National Vice President in Title Maintenance and paid-as Regional Vice President or a Regional Vice President in Title Maintenance and paid as an Area Manager, you are eligible to receive a VP Success Award as follows:

- Recognition Titled NVP, paid-as RVP: Arbonne will use your Region SuccessLine QV to determine whether you've earned your NVP Success Award and it will look at your Central Region to see if you've earned your RVP Success Award. You'll receive the greater one earned.
- Recognition Titled NVP/RVP paid-as AM: Arbonne will use your Area SuccessLine QV to determine whether you've earned your RVP Success Award.

Contact Customer Service immediately if you have questions or believe there was an error regarding your VP Success Award payment. Pursuant to Policy & Procedure 6.5 we are unable to make a correction after 60 days.

AMENDMENTS

Arbonne reserves the right to periodically amend or modify this SuccessPlan, the Policies & Procedures, Privacy Policy, and the Independent Consultant Application & Agreement (the Agreement). The Arbonne Independent Consultant agrees to abide by the Agreement and all amendments and modifications as set forth in the Agreement.

No Arbonne Independent Consultant of any status may alter, amend or waive any provision of the Agreement and any representation or statement to the contrary, or which is inconsistent with the foregoing, should not be relied upon and will not be binding on Arbonne.

KEY DEFINITIONS

Agreement: The contract between Arbonne and each Arbonne Independent Consultant, including the Independent Consultant Application & Agreement (as well as renewals thereof), the Policies & Procedures, the Arbonne SuccessPlan, the Independent Consultant Code of Ethics, Arbonne's online Legal Terms and Conditions (for those who enroll online), and Arbonne's Privacy Policy on Arbonne's website, each as may be amended by Arbonne from time to time as set forth in the Policies & Procedures.

Advanced Track Qualification: Arbonne allows you to complete your qualification for one level and in the same month, complete 1st step qualification for the next level. You may only use the pick-up credit and/or count QV from your promoted-out Managers/VPs for the level you are in qualification for and completing that month.

Arbonne Independent Consultant: Any individual who has signed and submitted an Arbonne Independent Consultant Application & Agreement to Arbonne that is accepted by Arbonne. Under this definition, the term Arbonne Independent Consultant refers to and includes all Independent Consultants, Managers and Vice Presidents.

Central Area: Your Central Area comprises you, your Central District, and all the Districts below you that have not yet reached the level of Area. When one of your Arbonne Independent Consultants reaches the level of Area Manager, then that Arbonne Independent Consultant (new AM) and all Arbonne Independent Consultants and Districts beneath him or her promote out from your Central Area to form their own Central Area – they are then considered your 1st Generation Area.

Central District: Your Central District comprises you, your personally registered Independent Consultants, and all other Independent Consultants registered by them and so on that have not yet reached the level of District. When one of your Independent Consultants reaches the level of District Manager, then that Arbonne Independent Consultant (new DM) and all Arbonne Independent Consultants beneath him or her promote out from your Central District to form their own Central District – they are then considered your 1st Generation District.

Central Nation: Your Central Nation comprises you, your Central Region and all the Regions below you that have not yet reached the level of Nation. When one of your Arbonne Independent Consultants reaches the level of National Vice President, then that Arbonne Independent Consultant (new NVP) and all Arbonne Independent Consultants beneath him or her promote out from your Central Nation to form their own Central Nation – they are then considered your 1st Generation Nation.

Central Region: Your Central Region comprises you, your Central Area and all the Areas below you that have not yet reached the level of Region. When one of your Arbonne Independent Consultants reaches the level of Regional Vice President, then that Arbonne Independent Consultant (new RVP) and all Arbonne Independent Consultants beneath him or her promote out from your Central Region to form their own Central Region – they are then considered your 1st Generation Region.

Client Commission: Commission paid on orders placed by your personal Clients, calculated at 35% of the suggested retail price of the orders, excluding product promotions and discounted product sets that may have reduced or no commission.

Discount: The percentage deducted from the suggested retail price (SRP) of Arbonne products to give the Arbonne Independent Consultant product cost (Business Aids and any product specials not included).

Generations: Whenever an Arbonne Independent Consultant in your SuccessLine achieves the level of District Manager or

above, they promote out to form their own Central (District, Area, Region or Nation, depending on the level achieved) and become part of your 1st Generation. At this time, the promoted Arbonne Independent Consultant, their entire SuccessLine, and their total Qualifying Volume (QV)/Retail Volume (RV) are no longer considered part of your Central. You will no longer be able to include their QV/RV in your Central Maintenance, Central Override or in your Performance Account calculations, but their RV will be available to you as a 1st Generation override.

Maintenance: Each paid-as level has a specific Central QV maintenance requirement to meet each month. If you do not meet the monthly maintenance volume requirement and you are unable to use any QV from your Performance Account to reach it, your paid-as title will be reassigned to the next paid-as title below on the 1st of the following month. Your recognition title will remain for the period of time specified in **Title Maintenance** following your paid-as title reassignment.

Overrides and Cash Awards: All overrides, commissions, and cash awards will be calculated at the end of the achievement month and paid the following month to all Arbonne Independent Consultants who qualified for such overrides, commission and cash awards. Arbonne may pay client and Preferred Client commissions more frequently during the month they are earned.

Override Volume (OV): Override Volume, on which overrides are calculated, is 65% of Retail Volume (RV).

Paid-As Title: The title at which you are paid within the Arbonne SuccessPlan regarding overrides, awards and other incentives. This title is based on your performance and may be different from the recognition title you currently maintain.

Performance Account (PA): The Performance Account is an account where Arbonne adds to or deducts from, each month, based on your Central QV Maintenance requirement and your actual Central QV monthly total. This QV account is only available to help you reach your monthly QV maintenance requirement when you fall short; however, you are not paid on this volume and it does not assist in helping you reach awards, qualifications for incentives, programs, or other management qualifications.

Personal Qualifying Volume (PQV): The Qualifying Volume (QV) achieved personally by an Arbonne Independent Consultant through sales under their personal Arbonne ID in a calendar month, including Qualifying Volume from sales to his or her registered Clients and Preferred Clients.

Pick-Up Credit: A Qualifying Volume credit applied each month to your SuccessLine QV for Independent Consultants and Central QV for District Managers and above for purposes of calculating QV for promotion to the next title. These credits do not generate compensation. Pick-up credits apply as follows:

- **Consultants in qualification for DM** – Maximum of one 650 QV pick-up credit, each applicable month during the qualification period, if you have a personally registered, paid-as District Manager or above.
- **DM in qualification for AM** – Maximum of one 2,500 QV pick-up credit, each applicable month during the qualification period, if you have a 1st Generation District Manager who is paid-as Area Manager or above. The pick-up credit of 2,500 is only applied after you've already reached 2,500 Central District QV. This rule only applies at this qualification level.
- **AM in qualification for RVP** – Maximum of one 10,000 QV pick-up credit, each applicable month during the qualification period, if you have a 1st Generation Area Manager who is paid-as Regional Vice President or above.
- **RVP in qualification for NVP** – Maximum of one 40,000 QV pick-up credit, each applicable month during the qualification period, if you have a 1st Generation Regional Vice President who is paid-as National Vice President.

Preferred Client: Preferred Clients register with Arbonne to purchase Arbonne products at a great value and participate in product promotions available to this special client base through the Preferred Client Program. Preferred Clients are not an Arbonne Independent Consultant, and are not eligible to receive commissions or overrides, or register others under the Arbonne SuccessPlan. QV generated by sales to a Preferred Client is included in the PQV of their direct Arbonne Independent Consultant.

Preferred Client Commission: Commission paid on orders placed by your personally registered Preferred Clients, calculated at 15% of the suggested retail price of the orders, excluding product promotions and discounted product sets that may have reduced or no commission.

Promotion Credit: A QV credit each month applied to your Central Region or Nation QV for each 1st Generation paid-as RVP/NVP to help you reach your RVP/NVP Maintenance and VP Success Award goals. 10,000 QV for each 1st Generation paid-as RVP and 40,000 QV for each 1st Generation paid-as NVP. These credits do not generate compensation.

Qualified Status: At all levels of the SuccessPlan, you need to achieve "Qualified Status" by accumulating 150 Personal Qualifying Volume (PQV) each month to receive overrides (500 PQV for paid-as Consultants to receive an override), awards and other incentives. "Qualified Status" is also required to be eligible for a promotion and to maintain the team management levels at Arbonne, which are District Manager and above.

Qualifying Volume (QV): Each Arbonne product carries a designated Qualifying Volume that is used to calculate qualifications, maintenance, product specials and campaign incentives. Starter Kits, Business Aids, sample packs, and certain product specials have no Qualifying Volume.

Reassignment: When your Performance Account is depleted or if you've reached your yearly QV limit, your paid-as title will be reassigned to the next lower level of management as of the 1st of the following month.

Recognition Title: The title at which you are recognized. This title may be higher than your current paid-as title if you are in title maintenance.

Retail Volume (RV): RV is the volume used to calculate overrides. All Arbonne products carry a designated RV value that Arbonne Independent Consultants earn through their purchase and sale of those products. Please note that Starter Kits, Business Aids, sample packs, and product specials have no RV.

Start Month: The calendar month in which an individual first becomes an Arbonne Independent Consultant or Preferred Client.

Suggested Retail Price (SRP): The price suggested by Arbonne for the sale of Arbonne products to Clients. Arbonne catalogues, websites and other product marketing materials state the SRP for each Arbonne product. Sales of products at SRP enable Arbonne Independent Consultants to earn a retail commission on Client and Preferred Client sales. These commissions are reduced for discounted product sets or other product specials.

SuccessLine: All the Arbonne Independent Consultants who have been registered below you, no matter how deep. This may also be called your downline.

SuccessLine Qualifying Volume (SLQV): Your PQV, plus the PQV from all the Arbonne Independent Consultants who have been registered below you, unless they have promoted to a higher title in the SuccessPlan. Then, the promoted Arbonne Independent Consultants and anyone registered below are excluded from your SLQV.

Title Maintenance: When your paid-as title is lower than your recognition title, then you are considered in title maintenance. You remain in title maintenance unless you re-promote to be paid at your recognition title, or if your title maintenance period below has expired.

- District Managers – 3 months
- Area Managers – 6 months
- Regional Vice Presidents – 9 months
- National Vice Presidents – 12 months

EARNINGS AT A GLANCE: COMMISSION & OVERRIDE SUMMARY

Think of each of these sections as separate "profit centers" for your business.

Client Commission	35%			
PC Commission	15%			
Consultant Override	6%*			
Overrides	District			
Central	8%			
1st Generation	8%			
2nd Generation	2%			
3rd Generation	1%			
	District	Area		
Central	8%	6%		
1st Generation	8%	6%		
2nd Generation	2%	1%		
3rd Generation	1%	1%		
	District	Area	Region	
Central	8%	6%	3%	
1st Generation	8%	6%	3%	
2nd Generation	2%	1%	2%	
3rd Generation	1%	1%	2%	
	District	Area	Region	Nation
Central	8%	6%	3%	1%
1st Generation	8%	6%	3%	1%
2nd Generation	2%	1%	2%	1%
3rd Generation	1%	1%	2%	1%
4th Generation				1%
5th Generation				1%
6th Generation				1%

*6% Consultant override is only paid on the OV of personally registered Independent Consultants when you accumulate 500 PQV that month. Once you become a District Manager, you now have a Central and overrides are paid on your entire Central team. Remember, you are part of your Central team, so the Central override is now also paid on the OV for your personal sales through your Arbonne ID, as well as from the sales to your registered retail Clients and Preferred Clients.

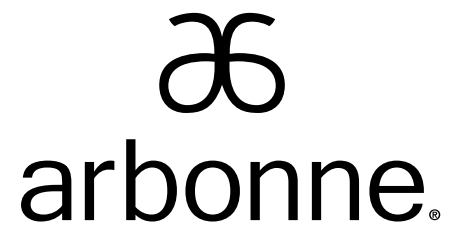

ON THE COVER:
ARBONNE INDEPENDENT CONSULTANTS

MARGARET KATCH
REGIONAL VICE PRESIDENT

HEATHER TOMLINSON
NATIONAL VICE PRESIDENT

LISETTE GUZMAN
INDEPENDENT CONSULTANT

RAYMONA LAWRENCE
AREA MANAGER



9557R18 01
©2020 ARBONNE INTERNATIONAL, LLC
ALL RIGHTS RESERVED. | ARBONNE.COM